

# **SPECIALTY TOOLS FOR THE HEAVY DUTY TECHNICIAN**



**The Innovator of Heavy Duty Specialty Tools,  
Mechanics Creepers and Lubrication Products**

## 49000 TRUCK SPRING CAGE BOLT SOCKET

Quickly Unlocks Truck Air Brakes.

Extra deep 3/4" socket loosens the cage bolt to unlock air brakes on trucks. Also removes the air brake booster for replacement. Use with a 1/2" drive or 7/8" hex. Can be used with an impact wrench. Shipping wt. 12 oz.

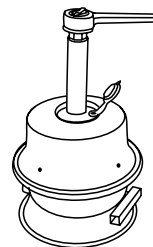

## 39110 PITMAN ARM REMOVER FOR TRUCKS

Quickly And Safely Removes Stuck Pitman Arms On Trucks 2 Ton And Larger.

The tool wedge opens the Pitman arm slots for easy removal. Can be used with an impact wrench.

Directions:

1. Remove the bolt and nut from the Pitman arm.
2. Insert both tool arms into the bolt hole.
3. Align the tool wedge with the slot and turn the center bolt.
4. Pull Pitman arm to remove.

Shipping wt. 2 lb. 4 oz.

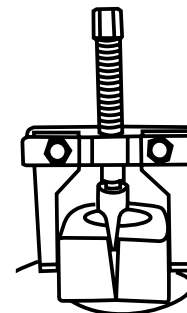

## 21520 TRUCK PEDAL DEPRESSOR

Depresses & Holds Clutch & Brake Pedals.

The two-piece, telescoping tool extends to pedal & locks in position. Brace the formed plate against the seat or steering wheel for support. Tool extends from 18 1/2" to 34 1/2". Shipping wt. 2 lb. 4 oz.

45980 Replacement Rubber Tip.

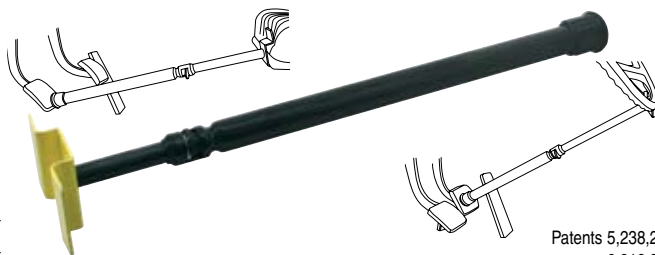

Patents 5,238,213  
6,912,938

## 42090 AIR LINE DISCONNECT SET

Disconnects Quick Connect Push-in Connectors Found on Heavy-Duty Truck Air Systems.

Disconnects air systems on brakes, suspension, steering, engine, transmission and other auxiliary equipment. Also disconnects other quick connect push-in fittings, including: flow control valves, check valves, shuttle valves, quick exhaust valves and other function control fittings in compressed air systems. Each tool is double-ended to disconnect air lines even in hard-to-reach areas. Angled end allows maximum leverage. Smaller end fits in tight spots. Shipping wt. 13 oz.

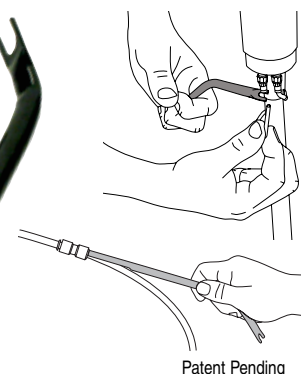
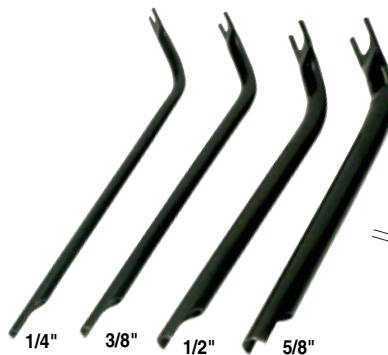

Patent Pending

## 28890 TRUCK ANCHOR PIN BUSHING DRIVER

Also Removes Truck Leaf Spring Bushings.

Pneumatic bushing driver set removes and installs truck and trailer anchor pin bushings and stuck anchor pins. Drive the bushing out with the small cone. Use the larger cone to install bushing to the proper depth. Ship. wt. 18 oz.

28900 Driver 28910 Remover Cone 28920 Installer Cone

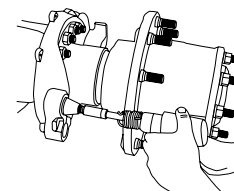

## 28950 TRUCK WHEEL STUD INSTALLER

Installs Most Truck Wheel Studs in Seconds.

Use with an impact wrench or ratchet. The tool body is equipped with a thrust bearing to easily pull the new wheel stud into place. Fits truck wheel studs up to 22mm (7/8") in diameter. Use the lug nut to tighten against the tool body to pull the stud in position. Shipping wt. 9 oz.

28970 Replacement Bearing and Dust Shield



Patent Pending

## 41500 PICKLE FORK KIT

For Separating Ball Joints, Tie Rods, Pitman Arms and Other Uses.

Six tools in one for exceptional versatility and value. Kit consists of three forks and two handles; one for hammering, the other for use with an air hammer (.401" shank). All forks are threaded to interchange with either handle. Forks are heavy-duty forgings, handles are heat-treated alloy steel. Shipping wt. 3 lb. 15 oz.



## 43620 BALL JOINT / TRUCK BRAKE ANCHOR PIN / U-JOINT PRESS

Tough Tool Makes easy Work of 3 Different Jobs.

Removes and installs press fit type ball joints found on cars and light trucks. Tool makes removing and installing truck brake anchor pins fast and easy. Also works on u-joints to press joint from the drive shaft for replacement. Tool comes with detailed instructions and a heavy-duty plastic storage case. Shipping wt. 16 lb. 1 oz.

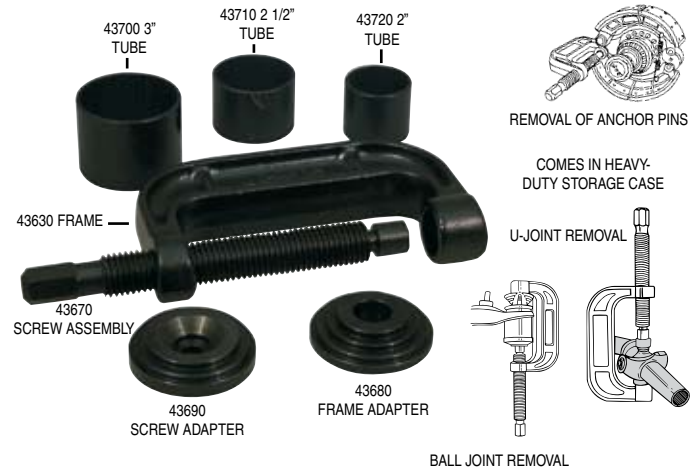

See price sheet for available replacement parts.

## 20500, 21000 & 21500 RING COMPRESSORS

Lisle Spring Clutch Eliminates Ratchet Problems.

The Lisle spring clutch assures a proper fit on the piston and a positive locking action.

**20500 Ring Compressor.** Range 3 1/2" to 7". (Height 3 1/2")

Shipping wt. 14 oz. NSN 5120-00-223-8848

**21000 Ring Compressor.** Range 3 1/2" to 7". (Height 7")

Shipping wt. 1 lb. 11 oz. NSN 5120-00-116-7676

**21500 Ring Compressor.** Range 7" to 10". (Height 7") Ship. wt. 2 lbs. 4 oz.

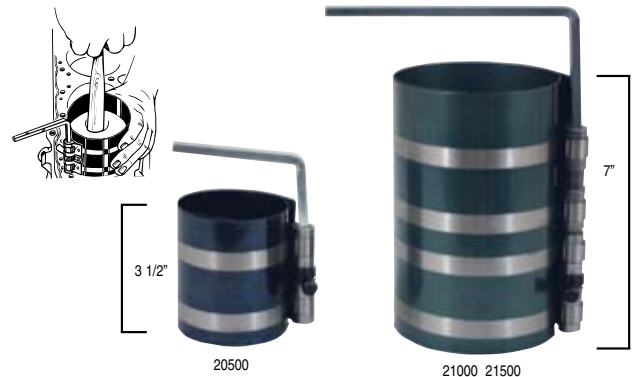

## 15000 ENGINE CYLINDER HONE

Best by Far - Yet Competitively Priced.

Micrometer head assures accuracy in feeding. Expands quickly to cylinder size with fast action rack and pinion. Bottom guard plate helps prevent stones from accidentally hitting the crankshaft. Universal joint action makes grinding of back cylinder easy. Clip-on stones and wipers are easily changed in a few seconds. Stones are available in five grits. Stone for Nikasil cylinders available. See chart. Use with heavy-duty 1/2" drill. Standard range 3" to 4 1/4". Big range (2 3/4" - 10 1/4") with additional rack sets and stone sets. Long 5" stones cut faster, more accurately. NSN 4910-00-554-9245. Shipping wt. 6 lb. 2 oz.

Includes the following: Cylinder hone body with 1 set of 15540 standard range rack (range is 3" to 4 1/4"). 1 set each of 15500 coarse stones and 15510 medium stones, cleaning brush and dressing paddle in a sturdy storage case.

See chart for rack sets and stone and wiper sets available. All stone and wiper sets consist of two stones and two wipers. Order by part number. All are 5 inches long, and weigh 7 oz.

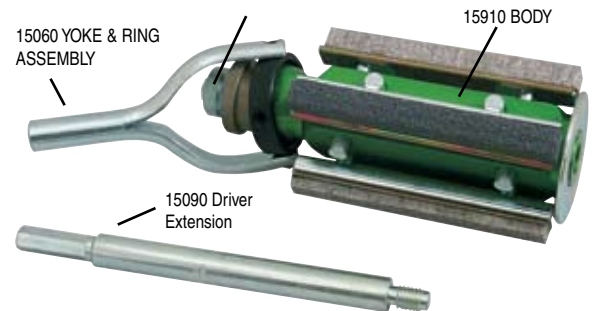

Cylinder Size Range	Rack Set Part No. Weight	Stone and Wiper Set Part Numbers				Special Hard Bond for Steel 150 Grit
		80 Grit	180 Grit	280 Grit	500 Grit	
2 3/4" - 3 3/4" 69.8 - 95mm	15550 1 lb.	15680	15690 * 15740	15700	----	----
3" - 4 1/4" 76.2 - 108mm	15540 1 lb. 2 oz.	15500	15510	15520	15990	15490
4" - 6 1/4" 100 - 158mm	15530 1 lb. 6 oz.	15500	15510	15520	15990	15490
6 1/8" - 10 1/4" 155 - 260mm	15560 1 lb. 14 oz.	15500	15510	15520	15990	15490

\* For Nikasil Cylinders

**75000 VACUUM PUMP****Heavy Duty Pump that is Field Repairable.**

The pump is made of one-piece zinc die cast material for durability and improved performance. Checks all vacuum operated components on car. Pump comes with a detailed, illustrated manual covering vacuum testing. Worn o-rings, seals and valves can be replaced with the 75400 repair kit. Shipping wt. 1 lb. 10 oz.

**75400 Vacuum Pump Repair Kit.** Shipping wt. 1 oz.

**75200 VACUUM TESTING / BRAKE BLEEDING KIT****Comes with 75000 Vacuum Pump & Complete Accessories for Vacuum Testing and Brake Bleeding.**

Pump is made of one-piece zinc die cast material for durability and improved performance. Order 75400 repair kit to replace worn out o-rings, seals and valves.

Shipping wt. 4 lbs. 8 oz.

**75400 Vacuum Pump Repair Kit.** Shipping wt. 1 oz.

**20750 REMOTE STARTER****Tough, Smooth-working, Reliable Switch.**

Features heavy gauge, rubber-covered copper wire. Depress button to jog or start the engine. Shipping wt. 6 oz.

**28850 CIRCUIT TESTER PLIERS****Dual Probe/Computer Safe/Polarity Indicator Tests Low Voltage 6 to 28 Volts.****Dual Probes**

Flip out probe enables you to check hard-to-reach connections. Probe can be flipped back when not in use. Probe with centering V design allows you to penetrate the center of the wire every time. Fits 16 gauge and smaller wire. Safe for use on 12 volt automotive computer circuits. Tool draws less than 19 mA. at 12 volts DC with an operating range of 6-28 volts. Shipping wt. 3 oz.

**55400 GROUNDING CLAMP****Provides a Better Ground Connection.**

Use with circuit testers, continuity testers, multimeters and other testers when a good ground is needed. Sharp tip on clamp penetrates rusted or painted metal surfaces. Shipping wt. 4 oz.

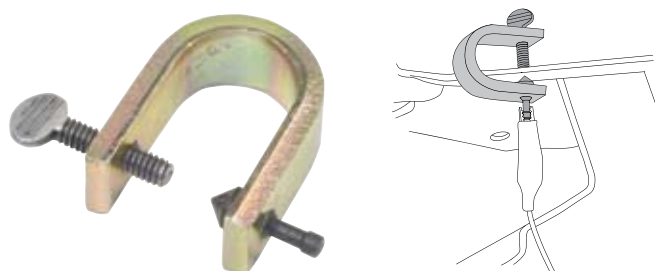



## 32900 HEAVY DUTY CIRCUIT TESTER / JUMPER

A 2-in-1 Tester that Tests Circuits up to 28 Volts and Works as a Jumper Wire for Power or Ground.

Heavy-duty circuit tester for checking low voltage up to 28 volts. By depressing the red button the tester becomes a jumper for powering electrical components or a ground. The probe, handle, cord and clamp are reinforced for durability. Comes with a strain relief spring on the cord.

Shipping wt. 7 oz.

**28440 Replacement Bulb**

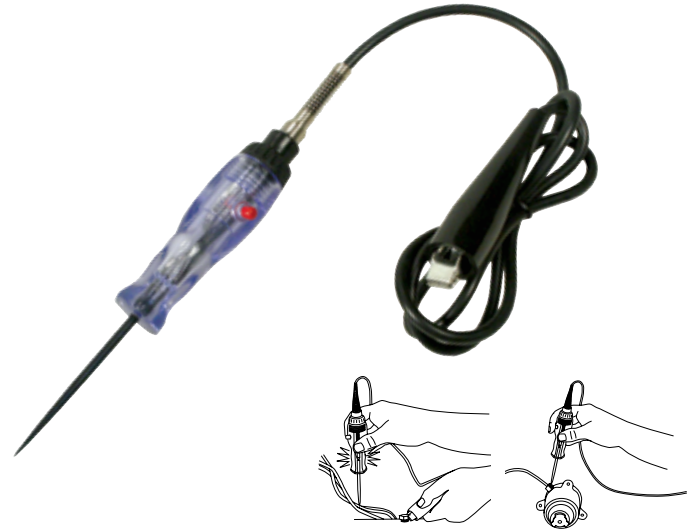

Patent Pending

## 24550 COMPUTER SAFE CIRCUIT TESTER

Also Indicates Polarity.

Safe for automotive computers. Won't damage sensitive electronic components. Draws less than 21 mA. at 12 volts DC. Operating range 3-28 volts. The red light indicates positive polarity, green indicates negative polarity. Shipping wt. 6 oz.

**24560 Replacement Bulb**



## 29500 HIGH-LOW CIRCUIT TESTER

Checks Both Low Voltage and Spark Plug Wires.

The low-side checks AC and DC current up to 28 volts with power on. The high-side checks spark plug wires without piercing. Complete with insulated clip. Shipping wt. 3 oz.

**19370 High End Bulb.** Shipping wt. 1 oz.

**26270 Low End Bulb.** Shipping wt. 1 oz.



CHECKING SPARK PLUG WIRES

## 32150 POWER / GROUND OUTLET

Provides a Convenient Electrical Ground and Power Source from the Vehicle.

Plug the tool into the cigarette lighter or power accessory receptacle. You now have a ground and power source on the dash. The plug light will come on to signal the plug is properly connected and both power and ground are available at the posts. For power, connect to the positive (+) terminal. For electrical ground, attach ground wire from the instrument to be grounded to the negative (-) terminal.

**32150 Power/Ground Outlet.** Skin-packed. Shipping wt. 3 oz.

**26270 Replacement Bulb.** Shipping wt. 1 oz.

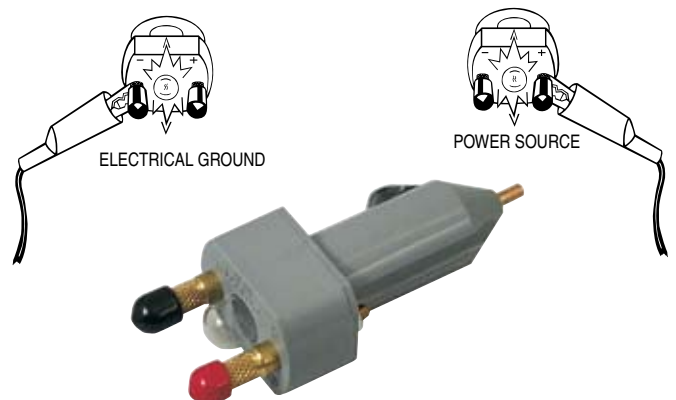

Patent 6,198,272

**56750 SEAL PULLER**

For Oil and Grease Seals.

Simply insert the tip of the tool behind the oil or grease seal, press and pull. Leverage works for you. Two size tips reach in and fit nearly all seal applications. Shipping wt. 15 oz.

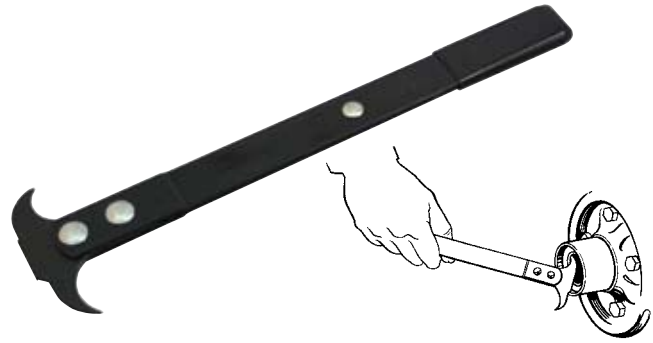

**56650 ADJUSTABLE SEAL PULLER**

Head Adjusts to 5 Positions.

Two hook sizes easily remove most oil and grease seals. Where clearance is a problem, remove the pin to reposition the head. The adjustable head works great on front wheel drive transaxles. Also works on front crankshaft seals without removing the radiator. Shipping wt. 15 oz.



**56680 Pull Pin**

Patent 7,039,993

**51200 SWIVEL JAW FILTER WRENCH PLIERS**

Jaws Swivel 90° in Either Direction to Access Most Oil and Fuel Filters.

Works where other oil and fuel filter pliers and wrenches don't. Jaws adjust to 7 positions, (30° increments) to fit most applications. Slip-joint handle offers a big range from 2-1/4" to 4-3/4" (57mm to 120mm). Sure grip teeth prevent slipping. Cushioned handles provide comfort. Shipping wt. 1 lb. 11 oz.

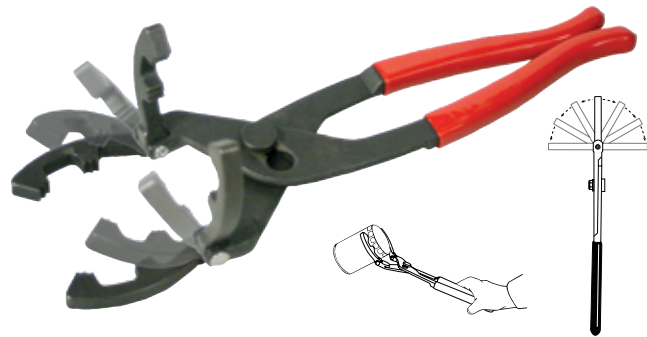

Patent 7,156,004

**50950 TRUCK AND TRACTOR OIL FILTER PLIERS**

Two Position, Slip Joint Handle for Greater Range, from 3 5/8" to 6".

Sure grip teeth prevent slipping. Cushioned handles provide comfort. Shipping wt. 1 lb. 13 oz.



Patent 5,595,094

**14600 FUEL FILTER SOCKET, 5.9L CUMMINS**

Helps Remove and Install Fuel Filters on 5.9 Liter Cummins Engines.

Use the low profile, 29mm socket on the raised hex on the fuel filter housing. 3/8" drive. Shipping wt. 3 oz.

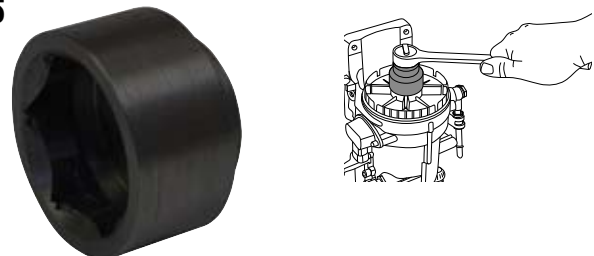

## 14500 OIL / FUEL FILTER SOCKET FOR 6.0L FORD DIESEL

Removes and Installs Filters on 6 Liter Ford Diesel Pickups.

The low profile socket fits both the 35mm and 36mm fuel and oil filters. Also works on Mini Cooper and some BMW oil filter housings as well as Mack Truck oil filter housings. The low profile socket works in confined spaces. 3/8" drive. Not for use with an impact wrench. Shipping wt. 4 oz.

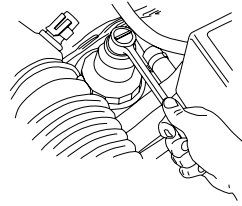

## 53250, 54200 & 54300 "SWIVEL GRIP" OIL FILTER WRENCHES

Handle Swivels to Clear Obstructions.

All three models feature the swivel handle, gripper "teeth" and 1" wide stainless steel band. The swivel handle makes it easy to turn filters in hard to reach locations. Vinyl covered handle.

**53250 Large Swivel Grip Oil Filter Wrench.** Range 4 1/8" - 4 1/2"

(104.7 - 112.7mm). Shipping wt. 12 oz.

**54200 Oil Filter Wrench for Cummins & Detroit Diesel Engines.** Range 4 5/16"

- 4 3/4" ( 110 -121mm ). Shipping wt. 13 oz.

**54300 Oil Filter Wrench for Caterpillar Engines.** Range 5 1/4" - 5 3/4" ( 133.5

- 146mm ). Shipping wt. 14 oz.

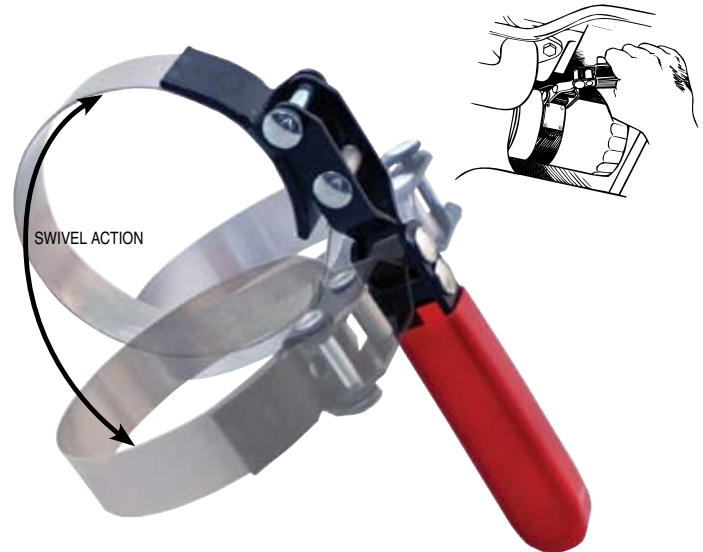

## 53100 ADJUSTABLE OIL FILTER WRENCH

For Trucks and Tractors. Fits John Deere, Case, Caterpillar, Mack, Detroit Diesel and others.

Tough, stainless steel band adjusts for extra range...won't slip. Professional quality. 1/2" square drive. Range 4 3/8" - 5 5/8" (111.1 - 142.8mm). Shipping wt. 14 oz.

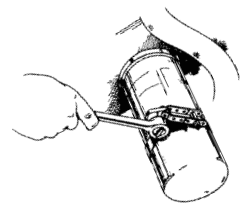

## 63500 "BIG RANGE" FILTER WRENCH

For Filters Up to 6" (152.4mm).

Adjusts quickly to fit any spin-on oil filter up to 6" diameter. Use with 1/2" drive or 3/4" wrench. Strong polypropylene belt. Shipping wt. 10 oz.

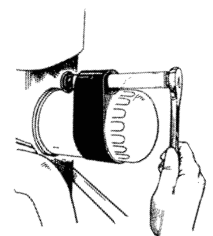

## 26550 & 27200 TORX® BIT SETS

Sizes for All Automobile Applications, T-10 through T-60.

All Torx bits are made of heat-treated alloy steel. 26550 - 9 pc. set includes T-10 through T-50. Our 27200 - 12 pc. set includes the same bits as our 9 pc. set, plus the T-47, T-55 & T-60 bits. T-10 through T-30 are 1/4" drive. T-40 through T-55 are 3/8" drive. T-60 is 1/2" drive.

**26550 9 Piece Torx Bit Set.** Shipping wt. 8 oz.

**27200 12 Piece Torx Bit Set.** Shipping wt. 15 oz.

\*BOTH SETS IN CONVENIENT VINYL HOLDER  
ALL BITS ARE AVAILABLE INDIVIDUALLY SKIN-PACKED.

26550 Includes Torx Size	Part No.
T-10	26560
T-15	26570
T-20	26580
T-25	26590
T-27	26600
T-30	26610
T-40	26620
T-45	26630
T-50	26640

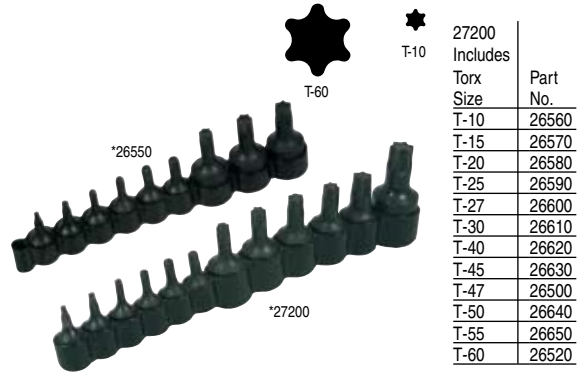

## 37600 SUPER TORX® SET

20% Stronger than One-Piece Torx Bits.

This set includes nine of the most popular Torx sizes for automotive applications. The six smaller bits are 1/4" drive, and the three larger bits are 3/8" drive. The set includes T-10, T-15, T-20, T-25, T-27, T-30, T-40, T-45 & T-50 in a convenient holder. The T-47, T-55 and T-60 bits are available individually. Shipping wt. 13 oz.



## 37940 12PC. SUPER TORX® BIT SET

Two-Piece Design for Greater Strength.

T-10 thru T-60 in one handy set. Six 1/4" drive; five 3/8" drive; one 1/2" drive. With convenient vinyl holder. All bits are available individually. Shipping wt. 1 lb. 5 oz.



## 26530 MASTER TAMPER RESISTANT TORX® BIT SET

Ten hex insert bits with two bit holders. Seven smallest bits are used with the 1/4" bit holder. Three largest bits use the 3/8" bit holder. All twelve pieces come in a convenient vinyl holder. Includes Torx® sizes T-10 thru T-55. Shipping wt. 7 oz.



## 26000 TAMPER RESISTANT TORX® BIT SET

Seven 1/4" Hex Insert Bits with 1/4" Drive Bit Holder. T-10 Through T-40.

Fits tamper-resistant Torx fasteners found on radio mountings, exterior mirrors, carburetors and other applications. Shipping wt. 3 oz.





## 26450 MASTER TORX® SET

34 Piece Set.

This master Torx set organizes all your Torx bits, tamper resistant Torx bits and Torx sockets in a low profile storage case with window. Shipping wt. 3lbs, 4oz.



### Torx Bits

Torx Size	Part No.
T-10	26560
T-15	26570
T-20	26580
T-25	26590
T-27	26600
T-30	26610
T-40	26620
T-45	26630
T-47	26500
T-50	26640
T-55	26650
T-60	26520

### Tamper Resistant Torx Bits

Torx Size	Part No.
T-10	26010
T-15	26020
T-20	26030
T-25	26040
T-27	26050
T-30	26060
T-40	26070
T-45	27560
T-50	27580
T-55	27600
1/4" Bit Holder	26080
3/8" Bit Holder	27630

### Torx Sockets

Torx Size	Part No.
E-5	26770
E-6	26780
E-7	26790
E-8	26800
E-10	26820
E-12	26830
E-14	26840
E-16	26850
E-18	26860
E-20	26870

## 26280 & 26750 TORX® SOCKET SETS

For External Torx Bolts.

**26280** includes 10 sizes, E5 through E20. The four smaller sizes are 1/4" drive; the next four sizes are 3/8" drive; the two largest sizes are 1/2" drive.

**26750** has seven sizes E-6 thru E-16. The three smaller sizes are 1/4" drive; the four larger sizes are 3/8" drive.

Made of heat-treated alloy steel. Sockets are kept in a convenient vinyl holder.

**26280 Torx Socket Set.** Shipping wt. 1 lb.

**26750 Torx Socket Set.** Shipping wt. 9 oz.



Part No.	Torx Size	Bolt Size
26770	E-5	#8, 4mm
26780	E-6	#10, 5mm
26790	E-7	5/16 stud
26800	E-8	#12 & 1/4", 6mm
26820	E-10	5/16", 8mm
26830	E-12	3/8", 10mm
26840	E-14	7/16", 12mm
26850	E-16	1/2"
26860	E-18	9/16", 14mm
26870	E-20	5/8", 16mm

SET INCLUDES CONVENIENT VINYL HOLDER. ALL SOCKETS ARE AVAILABLE INDIVIDUALLY SKIN-PACKED.

Part No.	Fits Torx Size	Most Common Bolt (Screw) Size
26780	E6	#8
26790	E7	#10
26800	E8	#12 and 1/4"
26820	E10	5/16"
26830	E12	3/8"
26840	E14	7/16"
26850	E16	1/2"

## 42150 & 42300 HEX KEY SETS

In a Handy Storage Case.

42150 Standard Set includes 12 heat-treated alloy steel hex keys. 42300 Metric Set includes 9 heat-treated alloy hex keys. Also available individually.

**42150 Standard Hex Key Set.** Shipping wt. 7 oz.

**42300 Metric Hex Key Set.** Shipping wt. 10 oz.

Part #	Size
42160	.05
42170	1/16"
42180	5/64"
42190	3/32"
42200	7/64"
42210	1/8"
42220	9/64"
42230	5/32"
42240	3/16"
42250	7/32"
42260	1/4"
42270	5/16"



Lisle Part #	Wrench Size
42310	1.5mm
42320	2mm
42330	2.5mm
42340	3mm
42350	4mm
42360	5mm
42370	6mm
42380	8mm
42390	10mm

## 42500 & 42650 LONG ARM HEX KEY SETS

In a Handy Storage Case.

Allows for longer reach for deep socket Allen-type screws. Also increases torque. 42500 includes 12 fractional hex keys. 42650 includes 9 metric hex keys. Heat-treated alloy steel. Also available individually.

**42500 Long Arm Hex Key Set - Standard.** Shipping wt. 10 oz.

**42650 Long Arm Hex Key Set - Metric.** Shipping wt. 13 oz.

Lisle Part #	Wrench Size
42520	5/16"
42530	1/4"
42540	7/32"
42550	3/16"
42560	5/32"
42570	9/64"
42580	1/8"
42590	7/64"
42600	3/32"
42610	5/64"
42620	1/16"
42630	.05"



Lisle Part#	Wrench Size
42660	10mm
42670	8mm
42680	6mm
42690	5mm
42700	4mm
42710	3mm
42720	2.5mm
42730	2mm
42740	1.5mm

## 13600 & 33850 HEX BIT SETS

Seven Piece Sets. 3/8" Square Drive.

High strength, heat-treated alloy steel bits are securely broached into chrome plated sockets. No set screws to tighten! Bit sets store in a convenient vinyl storage holder.

**13600 Hex Bit Set.** Shipping wt. 11 oz.

**33850 Metric Hex Bit Set.** Shipping wt. 11 oz.

ALL BITS ARE AVAILABLE INDIVIDUALLY SKIN-PACKED



13600 Individual Sizes:	33850 Individual Sizes:
13610	1/8"
13620	5/32"
13630	3/16"
13640	7/32"
13650	1/4"
13660	5/16"
13670	3/8"
33860	3mm
33870	4mm
33880	5mm
33890	6mm
33900	7mm
33910	8mm
33920	10mm

## 29200 & 30200 HAND IMPACT TOOL SETS

Loosens Rusted, Frozen Nuts, Bolts and Screws. Unique design delivers over 200 ft. lbs. of "Shock Torque." Can be reversed to tighten. Can also be used with impact sockets!

**29200 Hand Impact Tool Set.** 3/8" sq. drive with 3/8" drive bit holder; #1, #2, #3, #4 Phillips, and 3/8" straight slot bits. Shipping wt. 2 lbs. 10 oz. NSN 5120-01-072-2956

**30200 Hand Impact Tool Set.** 1/2" sq. drive with 1/2" drive bit holder; #1, #2, #3, #4 Phillips, and 3/8" straight slot bits. Shipping wt. 2 lbs. 10 oz. NSN 5120-01-072-2956



29200 IMPACT SET INCLUDES:		30200 IMPACT SET INCLUDES:	
29000	3/8" Impact Tool	30000	1/2" Impact Tool
29520	3/8" Bit Holder	30150	1/2" Bit Holder
29630	#1 Phillips Bit	29630	#1 Phillips Bit
30180	#2 Phillips Bit	30180	#2 Phillips Bit
29550	#3 Phillips Bit	29550	#3 Phillips Bit
30190	#4 Phillips Bit	30190	#4 Phillips Bit
30170	3/8" Straight Slot Bit	30170	3/8" Straight Slot Bit

## 49200 HEAVY DUTY INTERNAL / EXTERNAL SNAP RING PLIERS

Reversible Action for Internal and External Applications.

The heavy duty plier construction and larger tips are designed for larger snap rings. The tool quickly converts from internal to external use by pivoting the handles. Tough tool easily compresses internal rings and expands external rings. Conical tip ends prevent the snap ring from slipping off the tips. Ten tip sets in a handy plastic pouch are included to fit a wide range of snap ring sizes. Tips are easily interchanged by turning a set screw, wrench included. Shipping wt. 12 oz.

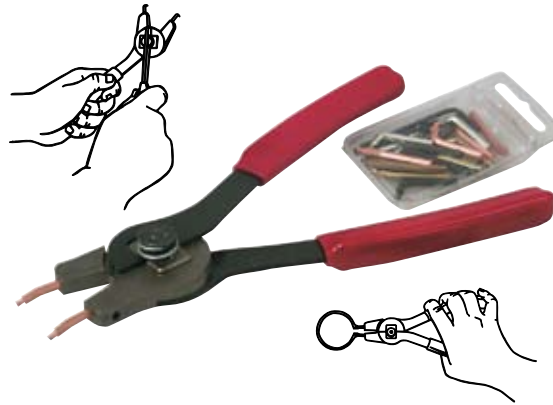

49460 Tip Set Includes Two Each of the Following Sizes:

Diameter	Angle
.060"	75°
.060"	15°
.075"	75°
.075"	15°
.090"	75°
.090"	15°
.108"	75°
.108"	15°
.125"	75°
.125"	15°

49460 Replacement Tips

Patent 5,515,587

## 46000 COMBINATION INTERNAL / EXTERNAL SNAP RING PLIERS

A handy combination tool for internal and external snap rings. Compresses internal rings in one position. Move the quick-change reversing lever to expand external rings. Comes with four sets of tips in a plastic box. Shipping wt. 7 oz.

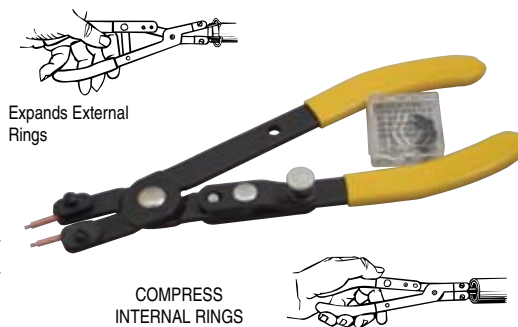

Expands External Rings

COMPRESS INTERNAL RINGS

EASY, QUICK CHANGE REVERSING LEVER



46250 Replacement Tip Set Includes:

- .045" straight tips
- .060" straight tips
- .045" 45 degree tips
- .035" 90 degree tips

46250 Replacement Tip Set. Shipping wt. 1 oz.

## 44900 LOCK RING PLIERS

For Removing and Installing All Types of Lock Rings.

Spreads lock rings commonly found on transmissions, master cylinders, brakes and other applications. Specially designed jaws are knurled on the end to prevent slipping. Shipping wt. 8 oz.



## 62900 SUPER OUT SET

Quickly Removes Frozen Bolts and Screws.

A SUPER STRONG extractor set made of a special hardened, shock-resistant tool steel. Works on both left and right hand threads. Super Outs cut their way STRAIGHT into bolts, eliminating wedging or further tightening of frozen bolts and screws. Five extractor sizes extract 1/4" to 1/2" and larger bolts and screws. Shipping wt. 4 oz.



ALL BITS ARE ALSO AVAILABLE INDIVIDUALLY SKIN-PACKED

Lisle Part No.	For Bolt Size	Use Drill Size
62560	1/4"	1/8"
62570	5/16"	11/64"
62730	3/8"	15/64"
62580	7/16"	9/32"
62590	1/2"	3/8"

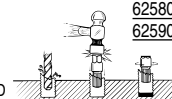

Patent 6,098,499

## 68100 DELUXE FEELER GAUGE

31 Blades. 1 Brass Blade .010".

Precision blades ensure accurate measurements. Blades from .0015" to .035" (.038 - .889mm) thickness are approximately 1/2" wide by 3 1/2" long. Shipping wt. 5 oz.

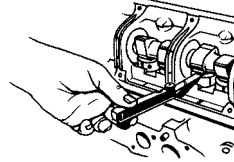

Blade Sizes			
Inches		mm	
.0015	.038	.016	.406
.002	.051	.017	.432
.0025	.064	.018	.457
.003	.076	.019	.483
.004	.102	.020	.508
.005	.127	.021	.533
.006	.152	.022	.559
.007	.178	.023	.584
.008	.203	.024	.610
.009	.229	.025	.635
.010	.254	.026	.660
.011	.279	.028	.711
.012	.305	.030	.762
.013	.330	.032	.813
.014	.356	.035	.889
.015	.381		

## 68000 MINI FEELER GAUGE

16 Steel Blades.

Precision blades ensure accurate measurements. Blades from .010" to .035" (.254 - .889mm) are approximately 1/4" wide by 1 3/4" long. Shipping wt. 1 oz.

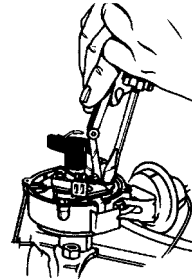

Blade Sizes	
Inches	mm
.010	.254
.012	.305
.013	.330
.015	.381
.016	.406
.017	.432
.018	.457
.020	.508
.022	.559
.024	.610
.025	.635
.026	.660
.028	.711
.030	.762
.032	.813
.035	.889

## 67950 STANDARD FEELER GAUGE

15 Steel Blades. One 2" Steel Rule.

Precision blades ensure accurate measurements. Blades are approximately 1/2" wide by 3 1/2" long. Shipping wt. 3 oz.

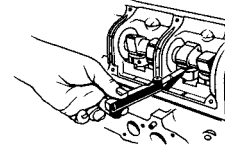

Blade Sizes	
Inches	mm
.002	.051
.003	.076
.004	.102
.005	.127
.006	.152
.008	.203
.011	.279
.012	.305
.013	.330
.014	.356
.016	.406
.018	.457
.020	.508
.022	.559
.025	.635

## 68050 VALVE TAPPET FEELER GAUGE

11 Offset Steel Blades.

Precision blades are offset at the proper angle for adjustment of valve tappets. Blades are approximately 1/2" wide by 4" long. Shipping wt. 3 oz.

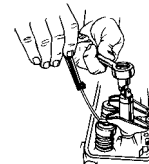

Blade Sizes	
Inches	mm
.008	.203
.010	.254
.012	.305
.013	.330
.014	.356
.015	.381
.016	.406
.018	.457
.019	.483
.020	.508
.026	.660

## 68150 GO-NO-GO FEELER GAUGE

22 Steel Blades.

Precision stepped blades have a .002" step for accurate settings. Blades from .004" to .027" (.102 - .686mm) are approximately 1/2" wide by 3 1/4" long. Shipping wt. 4 oz.

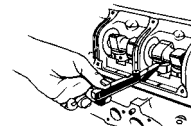

Blade Sizes							
Inches		mm		Inches		mm	
Low	High	Low	High	Low	High	Low	High
.004	.006	.102	.152	.015	.017	.381	.432
.005	.007	.127	.178	.016	.018	.406	.457
.006	.008	.152	.203	.017	.019	.432	.483
.007	.009	.178	.229	.018	.020	.457	.508
.008	.010	.203	.254	.019	.021	.483	.533
.009	.011	.229	.279	.020	.022	.508	.559
.010	.012	.254	.305	.021	.023	.533	.584
.011	.013	.279	.330	.022	.024	.559	.610
.012	.014	.305	.356	.023	.025	.584	.635
.013	.015	.330	.381	.024	.026	.610	.660
.014	.016	.356	.406	.025	.027	.635	.686

**11120 BATTERY BRUSH**

Two Tools in One.

Cleans dirt and corrosion from battery terminals and cable clamps. The external brush cleans cable clamps and internal brush cleans terminal posts. Case is made of high impact plastic that will not weaken in cleaning solutions. Shipping wt. 3 oz.



**54150 BATTERY TERMINAL & WIPER ARM PULLER**

Removes Battery Terminals and Bolted on Wiper Arms.

A dual-purpose puller. Easily removes stuck battery terminals. Tighten knurled cone to force jaws under the cable clamp. Turn center screw to lift clamp off terminal. Also removes bolted on windshield wiper arms that fit over a tapered spline. The puller screw pad is designed to fit the top of the spline post for easy pulling. Shipping wt. 10 oz.

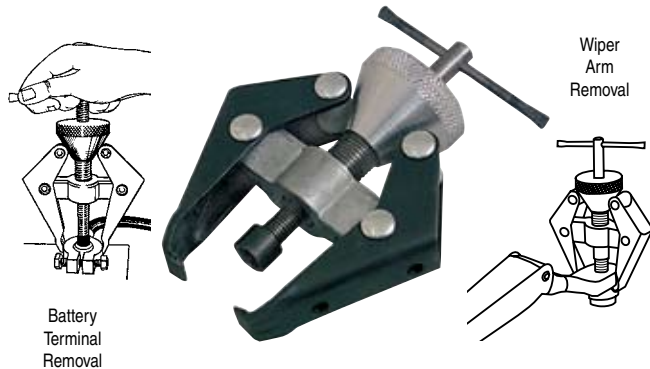

Patent 6,665,919

**57850 BATTERY CARRIER**

Lift and Carry Batteries Safely.

Sturdy steel jaws securely hold batteries. Spring-action handle turns lifting power into battery gripping pressure. Form-fitting handle provides a solid gripping surface for your hand. Carrier works on nearly all batteries, from motorcycles to boats. Saw-tooth jaw tips provide no-slip battery gripping power. Carrier grips the battery just below the top lip for good balance. A heavy-duty tool that is built to last. Shipping wt. 1 lb. 11 oz.



**14100 VALVE CORE TOOL**

Removes & Installs Valve Cores & Valve Core Caps.

The double ended core driver reverses in the tool body. The reversible driver fits both large & small valve cores. Use the reverse end to remove & install valve core caps. The long tool handle will access inside dual wheels. The lightweight aluminum body is equipped with a pocket clip. Shipping weight 1 oz.

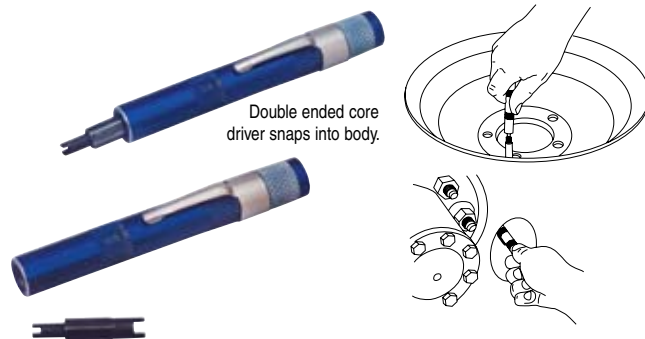

14110 Core Driver

**45900 HOOD PROP**

Works on All Makes of Cars and Trucks.

The three-piece, telescoping design allows the mechanic to hold the hood in the desired position. The tool telescopes from 18 1/2" to 46 3/4". Can be used from the side of car for better access to the engine compartment. Also great for body or repair work on door, trunk lids, or hatchbacks. Shipping wt. 2 lb. 3 oz.



45710 Repair Kit

45980 Large Rubber Tip

45990 Small Rubber Tip

REPAIR KIT 45710 INCLUDES 2 LEVERS AND 2 SPRINGS.

Patent 5,238,213



## 51000 HEAVY DUTY SCRAPER

Sharp Steel Blade Quickly  
Peels Off Carbon, Sludge.

Sharp, hardened steel blades remove carbon, old gasket material, adhesives, sludge and other hard-to-clean substances from blocks, heads, etc. Comes with three blades. 1", 1 1/2" and 2" widths. Tool will hold single edge razor blade for bumper stickers and decals. Shipping wt. 7 oz.

REPLACEMENT BLADES	
PART NO.	SIZE
51120	Six 1" blades
51130	Six 1 1/2" blades
51140	Six 2" blades

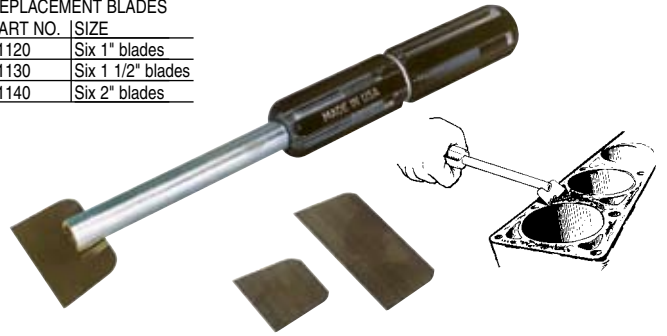

## 52000 RAZOR BLADE SCRAPER

At last, a scraper that is designed to reach in tight places. Comes with five carbon steel blades for removing stickers from windshields, bumpers, etc. Also comes with a plastic blade for use on safety plastic laminated windshields to prevent scratching. Spring-release allows easy interchange of blades. Reverse blade in holder for storage. Hollow handle stores all blades when not in use. Shipping wt. 7 oz.

**51320 Replacement Blades.** 5 piece set stainless steel blades.

**52080 Replacement Blades.** 5 piece set plastic blades.

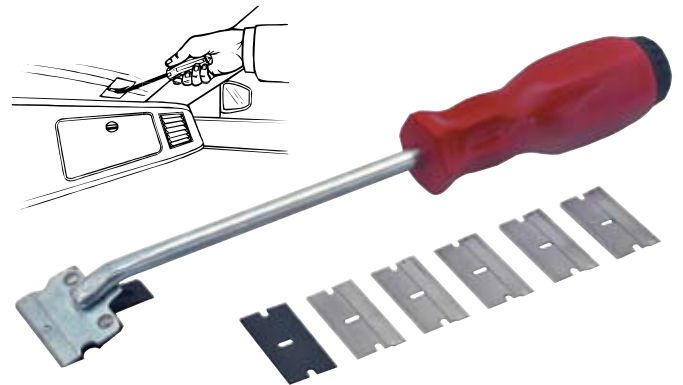

Patents 5,208,984 &  
D475,268

## 17100 FLAT BAND HOSE CLAMP PLIERS

Adjustable Jaws Fit All Clamp Sizes  
for Easy Removal and Installation.

This tool removes and installs flat band hose clamps used on heater and radiator hoses. Tips screw in and out to fit all clamp sizes. Ratcheting lock mechanism holds the clamp in an open position for easy removal and installation. Tips can be switched to accommodate different applications. Offset jaws allow access in hard-to-reach areas. Shipping wt. 1 lb. 1 oz.

**17120 Hollow Tip**

**17220 Slotted Tip**

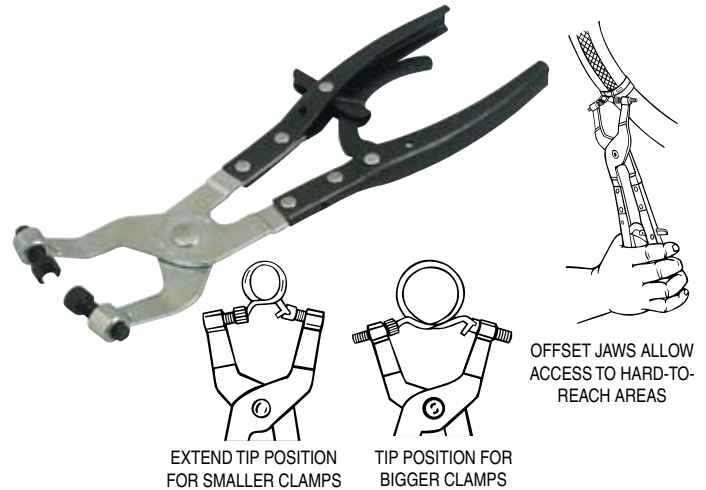

## 44480 HOSE CLAMP VISE

Vise Design Fits in Tight Spots. Vise is 3-5/8" Long and Opens to 2-1/8".

Tools are used to relieve clamp spring pressure in very tight spots. Vise is often left in place, with the clamp compressed, during service. Ramp on jaws guides tab of clamp into correct position and traps it in the slot for safety. Tighten knurled knob by hand or use 1/4" drive ratchet. Compact design works great in confined spaces. Shipping wt. 5 oz.

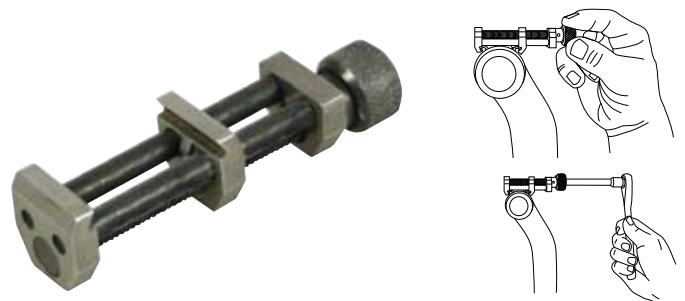

Patent Pending

## 11420 HOSE CUTTER

Cuts Flexible Hose up to 1 1/4".

The Hose Cutter will cleanly cut heater hoses, fuel lines, and other types of flexible hose up to 1 1/4". The stainless steel blade is reversible for double the life. Plier is made of glass-filled nylon for strength. Shipping wt. 11 oz.

11450 Replacement Blade.

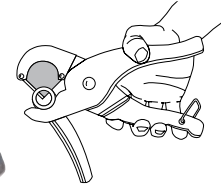

Patents  
D412,095  
5,987,750  
& 6,154,964

## 44000 TUBING BENDER

Bends 4 Sizes.

Easy to use with one end connected - or can be mounted in a vise. Exclusive nylon form prevents kinking or flattening. For 3/16", 1/4", 5/16" and 3/8" O.D. tubing. Not recommended for 3/8" steel. Shipping wt. 15 oz.

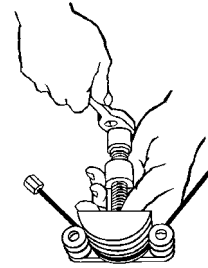

## 50000 MINI-CUTTER

Smooth Nylon Action Cuts Tubing Quickly.

Easy-to-use Mini-Cutter features all nylon construction, giving you smoother, easier operation & longer tool life. Used in tight places right on the car. For all types of metal tubing. Handles smallest tubing to 5/8" O.D. Completely non-corrosive. Shipping wt. 2 oz. NSN 5110-00-965-0878

50050 Replacement Cutter. Shipping wt. 1 oz.

50050 CUTTER

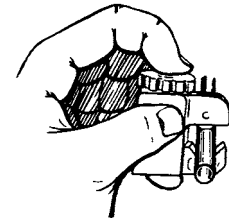

## 70500 TAP SOCKET SET

For Use in Restricted Areas.

Ideal for use in areas where a T-handle won't fit. Set of 8 sockets fits all number and fractional M.C.T.I. standard taps thru 1/2". Also fits 1/8" NPT taps and metric taps thru 12mm manufactured to M.C.T.I. standards. Sockets contained on a vinyl holder. Shipping wt. 15 oz.

ALL SOCKETS ARE AVAILABLE INDIVIDUALLY.

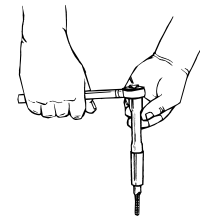

70500 Set Includes:

Lisle No.		Fits In.	Fits Metric	Shank Dia.	Sq. Size
70520	Socket #1	#1,2,3,4,6,8	1.6, 1.8, 2, 2.2, 2.5, 3, 3.15, 3.5mm	.141	.110
70540	Socket #2	#8	4mm	.168	.131
70560	Socket #3	#10	4.5, 5mm	.194	.152
70580	Socket #4	1/4"	6, 6.3mm	.255	.191
70600	Socket #5	5/16", 7/16"	7, 8mm	.323	.242
70620	Socket #6	3/8"	10mm	.381	.286
70640	Socket #7	1/2"	12, 12.5mm	.367	.275
70660	Socket #8	1/8" NPT		.437	.328

Patent 5,213,347

## 70940 TAP SOCKET SET

Three Larger Sizes in a Convenient Set.

The three largest tap sockets, also available individually, are now packaged in a three piece set. Ideal for use where a T-handle won't fit, especially in restricted areas. For larger, fractional M.C.T.I. standard taps. #9 socket is 5/8" (16mm), #10 is for 11/16" (18mm) and #11 is for 3/4". Sockets contained in a vinyl holder. Shipping wt. 1 lb. 4 oz.

ALL SOCKETS ARE AVAILABLE INDIVIDUALLY.



1/2" Drive

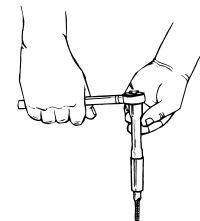

70940 Set Includes:

Lisle No.	Fits In.	Fits Metric	Shank Dia.	Sq. Size	
70860	Socket #9	5/8"	16mm	.480	.360
70880	Socket #10	11/16"	18mm	.542	.406
70900	Socket #11	3/4"	-----	.590	.442

Patent 5,213,347

## 31000, 31250 & 66500 MAGNETIC PICK-UP TOOLS

Will retrieve parts and tools from hard to reach places. Magnet shielded to concentrate magnetic field at end of tool. 31000 and 66500 have a super strong neodymium magnet. 31000 extends from 14 1/2" to 23 1/4". 31250 total length 9 1/2". 66500 telescopes from 4 1/2" - 16 1/4".

**31000 Magnetic Pick-Up Tool.** Shipping wt. 7 oz.

**31250 Magnetic Pick-Up Tool.** Shipping wt. 4 oz.

**66500 Telescoping Magnetic Pocket Pick-Up.** Shipping wt. 2 oz.

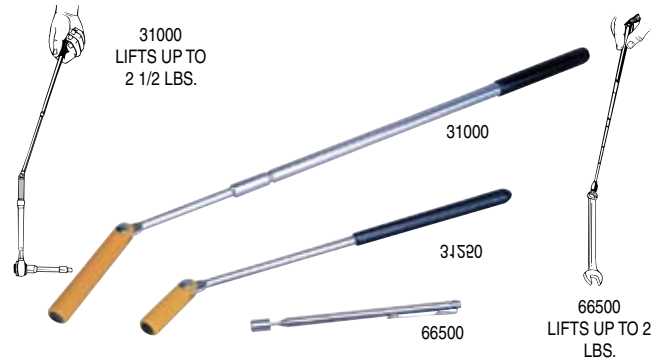

## 32050 TELESCOPING MIRROR

Enables You To See Around Corners.

2 1/4" diameter mirror swivels to any position. Length extends from 6 5/8" to 36 3/8". Has an insulated vinyl grip. Shipping wt. 5 oz.



## 31840 "O" RING AND SEAL PICK

Quickly Removes & Installs "O" Rings & Seals.

Tips are angled for hard-to-reach areas typically found around brakes, air conditioning and transmissions. Tips are hardened to stay sharp. Handle is knurled for a sure grip.

**31840 "O" Ring and Seal Pick.** Shipping wt. 2 oz.

## 31800 SCRIBE

For Marking Metal & Softer Material Surfaces.

Comes with straight and 90° points to mark in even the tightest places. Heat-treated carbon steel points provide durability. Knurled aluminum handle provides a sure grip.

**31800 Scribe.** Shipping wt. 2 oz.

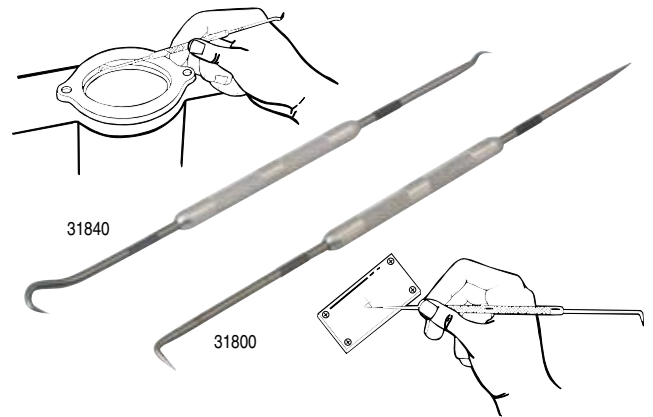

## 30280 AUTOMATIC CENTER PUNCH

Automatic Firing Action.

Automatic action fires to create a dimple when downward pressure is applied. No hammer is needed. Works on metal, plastic, wood and other materials. Pressure can be varied by turning the knurled knob. Hardened tool steel tip is replaceable. Length 5 1/2". Shipping wt. 2 oz.

**30290 Replacement Tip.**



## 22850 HOSE PINCHERS

A quick, easy way to pinch off vacuum lines, fuel lines, brake lines, etc. without damaging the line. Sold two per set. Shipping wt. 5 oz.



**35900 LED FLEXIBLE FLASHLIGHT**

**LED Bulb Lasts For Up to 100,000 Hours.**

Flexible wire works around obstructions and holds the shape you give it. White light brightly illuminates even the tightest work areas. Uses 3 AAA batteries not included.

Shipping wt. 2 oz.

**35910 Replacement Bulb Assembly.**



**32250 FLEXIBLE FLASHLIGHT**

**Shines Where Other Lights Can't!**

Flexible wire holds the shape you give it. Focused high intensity bulb (only 1/4" in diameter) fits into the tight spots. Uses two AA batteries not included. Shipping wt. 3 oz.

**32310 Wire and Bulb Assembly.** Shipping wt. 1 oz.

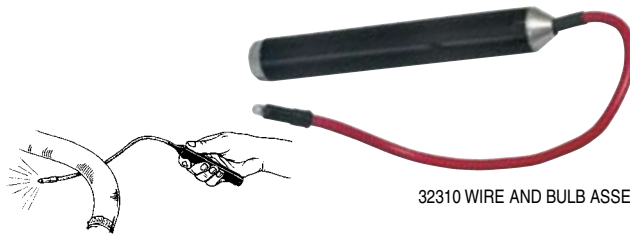

32310 WIRE AND BULB ASSEMBLY

**50350 SIDE WINDER AIR HOSE REEL**

**Coil & Uncoil Your Air Hose Neatly & Quickly**

The Side Winder Air Hose Reel provides a large 10" diameter reel to prevent tight coils in your air hose. Two built-in tool hangers keeps air chuck, blow gun or other air tools handy. The 1/4" NPT brass swivel keeps air flowing freely & handles up to 250 P.S.I.. A coil spring brake keeps reel from unrolling, yet allows easy dispensing of hose. Versatile installation — can be fastened in any direction — on or under a bench, on a wall, from the ceiling, on a compressor or on a service truck. The all steel construction with durable powder baked paint finish is made to last.

Supplies 28 C.F.M. at 90 P.S.I. Reel holds 150 feet of 5/8" O.D. hose or 100 feet of 3/4" O.D. hose. Dimensions: Diameter 17 3/4", Width 11", Height 19".

Shipping wt. 9 lb. 3 oz.

**50310 Swivel Joint. 50400 Handle Screw. 50410 Handle.**

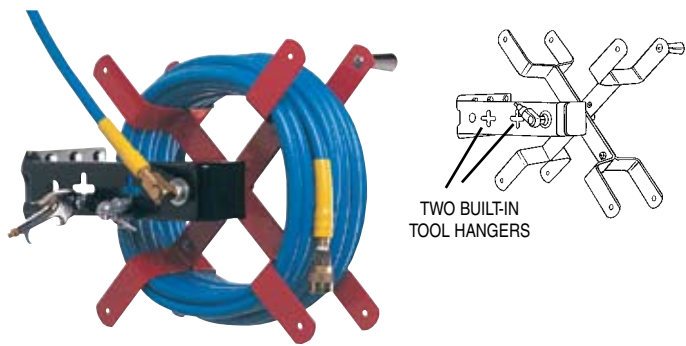

TWO BUILT-IN TOOL HANGERS

**Air Hose and Air Tools Not Included.**



Patents 5,666,992 & 5,732,733

**22500 THERMOSTAT GASKET CLEANER**

**Cleans All Hard To Reach Gasket Surfaces.**

Use with a die grinder to quickly clean gasket surfaces on Dodge pickups, oil pans, water pumps and other inaccessible applications. The tool is equipped with a floating guide shaft so the user can steer the abrasive pad around the gasket surface. Includes two replaceable abrasive pads, plus interchangeable short shaft. Shipping weight 4 oz.

**22570 Abrasive Pad**

**22560 Roll Lock Holder**

**22580 Short Driver Extension**

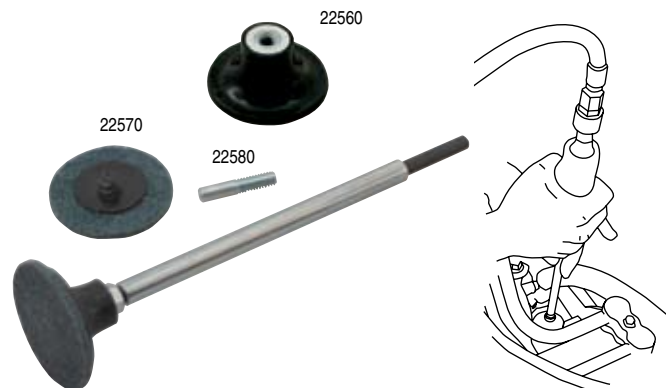

Patent 7,001,255



## 28500 STRAP WRENCH

Loosen or Tighten Cylindrical or Rectangular Objects.

Handy, self-tightening strap wrench won't slip. Works great for installing or removing timing belt sprockets or belt pulleys. Range from 1" to 6 5/8" round. Tensile strength of strap is 1350 P.S.I. Handle is made of glass-filled polypropylene which provides superior strength. Shipping wt. 10 oz.



Patent 6,101,903

## 59000 RATCHETING SERPENTINE BELT TOOL

Releases Tension on Serpentine Belts With a Spring Loaded Idler Pulley.

Ratcheting head with freewheel position allows maximum leverage. Set ratcheting head to the middle or neutral/freewheel position and once maximum travel point is reached simply click lever into place to lock the ratchet mechanism. Comes with extension for hard-to-reach idler pulleys. This tool will work where conventional ratchets or breaker bars won't fit due to limited access.

Tool set contains six sockets, two square drives and extension. Shipping wt. 2 lbs. 10 oz.

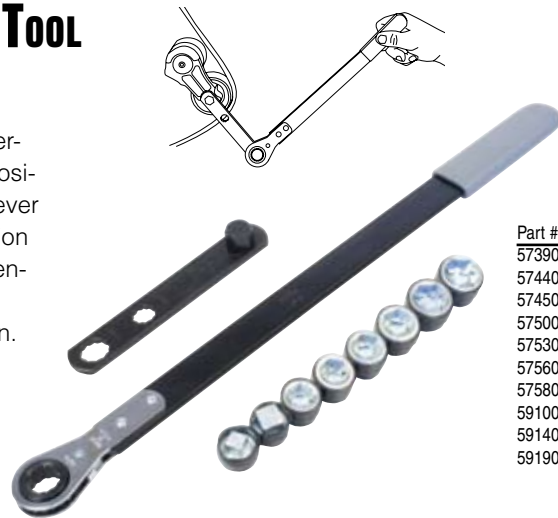

Part #	Description
57390	14mm Socket
57440	15mm Socket
57450	18mm Socket
57500	13mm Socket
57530	3/8" Square Drive
57560	1/2" Square Drive
57580	16mm Socket
59100	Extension
59140	19mm Socket
59190	Handle Assembly

Patent Pending

## 21260 ARM GLOVE

Total Hand and Arm Burn Protection.

The heat resistant Kevlar® material protects hands and arms from hot surfaces. This enables work on hot engines and exhaust systems without waiting. Works on both right and left hands. The glove portion is coated with a vinyl tread for greater gripping power. Extends to 24". Washable. Shipping wt. 3 oz.



Kevlar® is a trademark of DuPont.

## 18700 HOT SLEEVE

Protects Arms from Burns While Working Around the Engine.

Made of durable, heat-resistant Kevlar®. Double wall construction for added heat protection. Will protect hand and forearm from hot objects. Will work on either right or left arm. Sleeve is washable. Shipping wt. 3 oz.



Kevlar® is a trademark of DuPont.

## 34400 EXHAUST / TAILPIPE STRETCHER

Stretches All Pipe Including Stainless Steel.

Use with an impact wrench to quickly stretch pipes. Two collet sets fit pipes from 1 5/8" to 2 7/16". Can be used on the car.

The pipe stretcher is a convenient, inexpensive alternative to hydraulic pipe expanders. Additional collets (5) extend range to 4 1/4". (Not included in 34400 set.) Shipping wt. 4 lb. 10 oz.

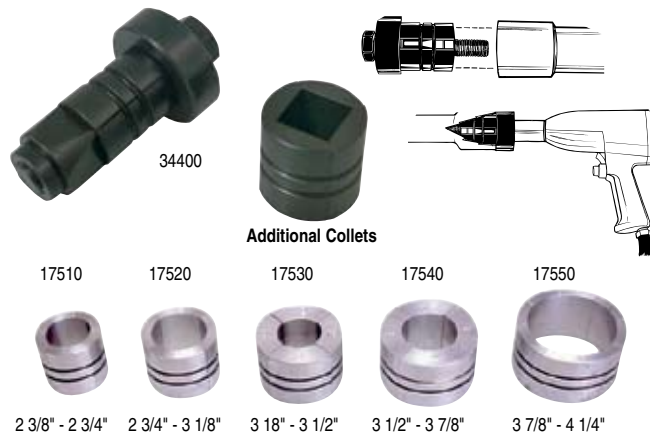

17510 Extender #1. Shipping wt. 7 oz.

17520 Extender #2. Shipping wt. 8 oz.

17530 Extender #3. Shipping wt. 1 lb.

17540 Extender #4. Shipping wt. 1 lb. 3 oz.

17550 Extender #5. Shipping wt. 12 oz. (must be used with 17530)

## 75500 COMBUSTION LEAK DETECTOR

Quickly Pinpoints Combustion Leaks.

Detects bad head gaskets, cracked blocks, & cracked or warped heads. Fluid changes from blue to yellow when exposed to combustion gases from the radiator. Connect the hose to any vehicle vacuum line. Place tapered end of tool into radiator opening. With the engine running, the vehicle vacuum or the vacuum pump draws vapors through the indicating fluid for testing. Shipping wt. 1 lb. 14 oz.

75630 Replacement Fluid. 16 fluid oz



Patent 6,806,092

## 75730 COMBUSTION LEAK DETECTOR FLUID FOR DIESEL

Detects Combustion Leaks on Diesel Engines.

Use the diesel leak detector fluid with the Lisle 75500 Combustion Leak Detector. Indicating fluid changes from red to yellow when exposed to diesel combustion gases in the radiator. Contains 16 fluid oz. Shipping wt. 1 lb. 4 oz



Patent 6,806,092

## 20130 MAGNETIC GLOVE DISPENSER

Magnetic glove dispenser conveniently attaches to your toolbox or any ferrous metal surface. Two large magnets hold the dispenser in place. Or, mount it on a wall using the screw slots provided. Fits all common sizes of disposable rubber glove boxes, both 50 and 100 packs. The dispenser has 3 adjusting springs which can be adjusted as necessary to hold the various box sizes. Made of powder coated steel. Shipping weight 1 lb. 10 oz.

Available in 6 pack boxes only for product protection.

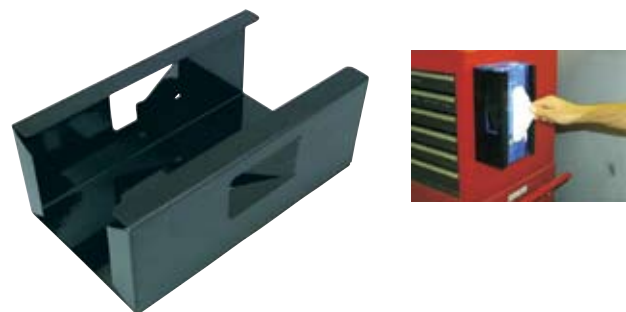

Patent 6,820,753

## 40200 & 40210 3/8" MAGNETIC SOCKET HOLDERS

**Organizes 3/8" Fractional & Metric Sockets.**  
 Twenty-eight socket compartments that allow you to keep your 3/8" standard and deep sockets in one convenient holder. Holds sockets up to 1" or 24mm. Design of holders leaves sockets exposed for easy identification. Powerful magnets securely hold sockets in tray, & tray to any steel surface. Made of strong ABS plastic. Fits most 3/8" sets.

**40200 3/8" Magnetic Socket Holder, Red.** Shipping wt. 2 lb. 3 oz.

**40210 3/8" Magnetic Socket Holder, Green.** Shipping wt. 2 lb. 3 oz.

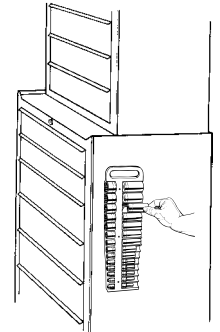

Sockets Not Included

Patents 5,313,181  
 5,343,181  
 5,500,631

## 40900 & 40990 1/2" MAGNETIC SOCKET HOLDERS

**Organizes 1/2" Chrome & Impact Sockets.**  
 Twenty-two socket compartments allow you to keep your 1/2" standard and deep sockets in one convenient holder. Holds sockets up to 1" or 20mm. Design of holders leaves sockets exposed for easy identification. Powerful magnet holds sockets in tray. Rubber feet protect tool box from scratching. Made of strong ABS plastic. Will fit impact sockets.

**40900 1/2" Magnetic Socket Holder, Red.** Shipping wt. 2 lb. 9 oz.

**40990 1/2" Magnetic Socket Holder, Green.** Shipping wt. 2 lb. 9 oz.

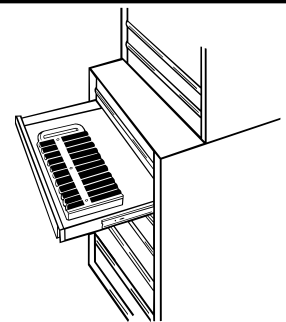

Sockets Not Included

Patents 5,313,181  
 5,343,181  
 5,500,631

## 21300 & 21400 MAGNETIC TOOL HOLDERS

**21300 - 13" Length. 21400 - 24" Length.**  
 Powerful magnet holds even heavy hand tools. Ideal for both home and shop. Mounting screws included.

**21300 13" Magnetic Tool Holder.** Shipping wt. 2 lb. 4 oz.

**21400 24" Magnetic Tool Holder.** Shipping wt. 4 lbs. 4 oz.

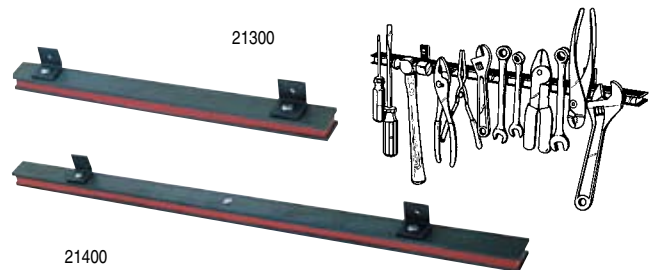

## 49960 LOCKING AIR TOOL HOLDER

**Organize Air Tools with this Lockable Tool Holder**  
 Tool can hold up to five pneumatic tools in a 10" space. Comes with five slots that fit all popular quick connect fittings from Milton, Lincoln, Amflo and others. Can be mounted on a tool box, cart or wall for easy access. Locking feature protects your air tools from theft (provide your own lock). Durable powder-coated finish. Shipping wt. 13 oz.



Patent Pending

**17432 18 GALLON OIL LIFT DRAIN**

**Quick Release Height Adjustment.**

Translucent jug holds 18 gallons and will not warp with hot oil. Rolls easily with four heavy-duty 2 1/2" wheels. Metal tubes extend working area from 36 1/2" to 77". Drains from the bottom with a brass drain valve. Large 15" funnel has a built in strainer to catch drain plugs. Optional 17442 Oil Pump Kit not included. Shipping wt. 21 lbs.

11302 Funnel

17382 Wheel

17402 Cap

17442 Oil Pump Kit

17812 Brass Ball Valve



17442 Oil Pump Kit



Quick-Release Height Adjustment

U.S. Patent 6,367,586  
U.S. Des. 429,160

**17892 TRANSMISSION DRAIN FUNNEL**

Heavy-duty plastic lift drain funnel extends the catch area of any lift drain. The funnel catches any loose parts. Flexible, if run over it will return to its original shape. Super Transmission Drain Funnel fits the Ford E 40D and others. The fluted design can be used for draining oil filters. Dimensions, 22" x 23". 12 per Master Pack. Shipping wt. 17 lb. 4 oz.



**19122 TRUCK DRAIN ON WHEELS**

**Use This Heavy Duty Drain To Drain Large Capacity Crank Cases.**

Holds 60 quarts. Equipped with 4 rollers & a handle for transport & positioning under trucks. The sides curve inward to keep oil from spilling during movement. Convenient handles & pour spout facilitate oil evacuation. Rolls under most all cab over axles so oil can be changed without jacks or jack stands. Overall height 10", width 24 1/2", length 43". Shipping weight 22 lb.

17382 Replacement Roller



Patent 6,874,549

**19852 TRUCK & TRAILER WHEEL PAN**

**Catches Oil from Wheel Hubs After Removing Cap.**

Prevents oil mess during wheel repair. The pan fits rims with 13 3/4" ID and larger. Handle compartments hold hub nuts out of the oil. Made of polypropylene for durability. Will not warp if oil is warm. Capacity 88 ounces. 8 per Master Pack. Shipping wt. 6 lb. 5 oz.



Patent 6,454,121



## 17962 FILTER PRELOAD PAN

Used to Move Truck Oil Filters from a Filling Location to the Vehicle for Installation.

Many truck oil filters are to be filled with oil before installing the filter at an oil change interval. This pan has cutouts to fit the most popular truck filter sizes. This design keeps the filters from tipping over while transferring them to the job. Ribs in the bottom of the pan also allow the user to place used filters in the pan for draining. Handles and spout make pouring of any excess or drained oil easy.

Shipping wt. 9 lb. - Master Pack of 3.



Patent Pending

## 17942 & 17952 4.5 GAL. PAN

Now with Built-in Ribs for Draining Filters in the Pan.

For easy transfer of liquids. High-density polyethylene material is resistant to chemicals and solvents, and is easy to clean. 1" wide diameter spout for quick and easy pouring. The anti-splash lip and baffles help prevent spilling when carrying or pouring. Comes with large, easy-grip handles. Two colors: 17942 is black for oil and 17952 is green for anti-freeze.

**17942 4.5 Gallon Oil Drain Pan, Black.** 8 per Master Pack. Ship wt. 21 lbs.

**17952 4.5 Gallon Oil Drain Pan, Green.** 8 per Master Pack. Ship wt. 21 lbs.

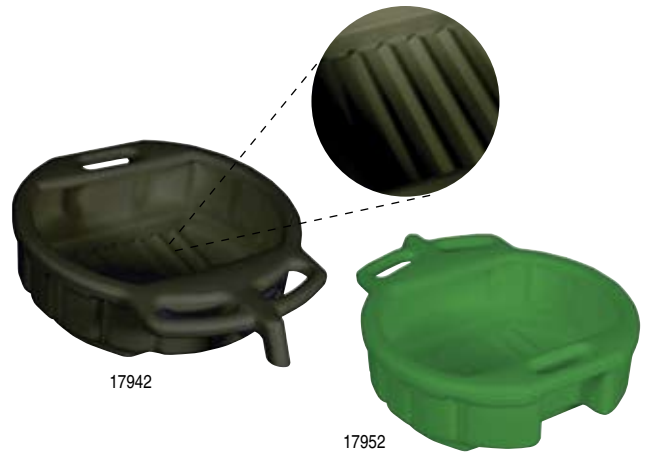

17942

17952

## 38750 No SPLATTER PAD

15" Diameter Pad Protects Floors & Work Area from Messy Oil Splatter.

Insert 15" diameter pad in funnel or oil pan before oil change to eliminate oil splatter. Porous material allows fluid to quickly pass through into funnel or pan. Pad material resists engine oil, transmission fluid, coolant, brake fluid, brake cleaner, gear oil and other solvents. 15" fits all standard oil lift drain funnels and oil pans. Pad can be trimmed for perfect fit. Important: Not for coolants or fluids that will be recycled in the vehicle. Material fibers may contaminate the fluid. 8 per Master Pack. Shipping wt. 8 oz.



Patent Pending

## 38780 No SPLATTER PAD

22" Square Pad Protects Floors & Work Area from Messy Oil Splatter.

Insert 22" square pad in transmission drain funnels or larger oil drain pans, before oil change to eliminate oil splatter. Porous material allows fluid to quickly pass through into funnel or pan. Pad material resists engine oil, transmission fluid, coolant, brake fluid, brake cleaner, gear oil and other solvents. 22" fits all standard transmission drain funnels and larger size drain pans. Pad can be trimmed for perfect fit. Important: Not for coolants or fluids that will be recycled in the vehicle. Material fibers may contaminate the fluid. 6 per Master Pack. Shipping wt. 1 lb. 6 oz.

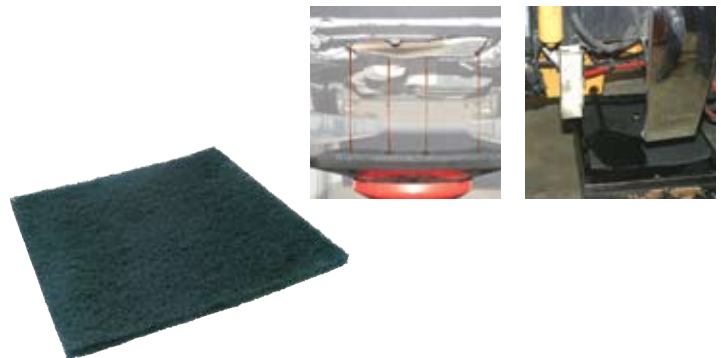

Patent Pending

## 92102, 93102 & 94102 LOW PROFILE PLASTIC CREEPERS

Built for Strength & Comfort

This body-fitting design was developed through testing on many body types to provide optimum comfort. Creeper body is 2" longer for a better fit. Urethane rollers are inserted into steel bushings which are molded into the creeper body. Provides added strength and easy roller replacement. Low profile, 7/8" floor clearance. Easy to clean surface is resistant to solvents, greases and fuels. Dimensions: Length 38", Width 17 1/2", Height 4".

- 92102 Red Plastic Creeper. Shipping wt. 10 lb. 8 oz.
- 93102 Yellow Plastic Creeper. Shipping wt. 10 lb. 8 oz.
- 94102 Blue Plastic Creeper. Shipping wt. 10 lb. 8 oz.
- 92132 2" Pop-in Wheel for Plastic Creeper
- 96412 Headrest



## 92032, 93032 & 94032 LARGE WHEEL CREEPERS

Bigger Wheels for a Better Ride.

Our popular plastic creepers are now available with larger, 4" pop-in urethane wheels. The larger wheels provide a much smoother ride on cracked or uneven floor surfaces, over floor debris and under heavy loads. Also rolls better on regular floor surfaces. The creeper body is the same as our low profile plastic creeper models 92102, 93102 and 94102.

- 92032 Large Wheel Plastic Creeper, Red. Shipping wt. 14 lbs. 8 oz.
- 93032 Large Wheel Plastic Creeper, Yellow. Shipping wt. 14 lbs. 8 oz.
- 94032 Large Wheel Plastic Creeper, Blue. Shipping wt. 14 lbs. 8 oz.
- 96572 4" Pop-in Wheel
- 96412 Headrest



Dimensions: length 38", width 17 1/2", height 8 5/8", floor clearance 3 3/4".

NOTE: You can interchange or retrofit your conventional Lisle plastic creepers, models 92102, 93102 and 94102 with six 96572 4" rollers.

Patent D406,684

## 93402 CREEPER SEAT/STEP

Ergonomic Design With A 300 Lb. Capacity That Can Be Rotated Forward Onto Rubber Feet To Make A Stable 14" Tall Step.

Spacious storage tray below the seat keeps tools, test equipment and parts within easy reach. Perfect for brake and tire service, body work, etc. Wheels pop into tubular steel legs with an outrigger design for added stability. Shipping wt. 21 lbs..



Patent Pending

## 95002 FOLD UP CREEPER

The Padded Vinyl Creeper Adds Comfort and Protection on the Job.

Works great on off road situations and under a vehicle where no jacks or lifts are used. Folds up and hangs for convenient storage. Shipping wt. 2 lbs. 15 oz.



Dimensions:  
Unfolded 18" x 48",  
Folded 18" x 24".

## 96302 42" PADDED LOW PROFILE STEEL CREEPER

Our most comfortable creeper. A fully padded creeper on a 42" tubular steel frame. Pad is made of heavy-duty vinyl and offers maximum comfort. Comes with four 2" ball bearing wheels. Shipping wt. 17 lb. 8 oz.

96132 2" Wheel. Shipping wt. 6 oz.

96322 Replacement Padded Board and Headrest



Patents 5,174,592  
5,330,209

## 96202 42" LOW PROFILE STEEL CREEPER

Quality 1/2" plywood bed on an expanded 42" tubular steel frame. Comes with four 2" ball bearing wheels and an extra large headrest. Shipping wt. 14 lbs.

96132 2" Wheel. Shipping wt. 6 oz.

96242 Replacement Headrest



Patents 5,174,592  
5,330,209

## 96102 36" LOW PROFILE STEEL CREEPER

Standard 36" length on tubular steel frame. Bed is high quality 1/2" plywood. Comes with four 2" ball bearing wheels for a smooth, easy glide. Shipping wt. 12 lb. 4 oz.

96132 2" Wheel. Shipping wt. 6 oz.

98112 Replacement Headrest



Patents 5,174,592  
5,330,209

## REPLACEMENT ROLLERS AND WHEELS

The 96132 2" oil resistant plastic wheel is standard on all Lisle steel creepers. This low-profile wheel comes with a cap nut and lock washer to prevent loosening. The 92132 2" Pop-in Wheel is standard on our new style plastic creepers. 96572 Large creeper wheels have a 4" diameter urethane rollers for a better ride.

92132 2" Pop-in Wheel for Plastic Creepers. Shipping wt. 6 oz.

96132 Wheel for Steel Creepers. Shipping wt. 6 oz.

96142 Cap Nut for 96132. Shipping wt. 1 oz.

96572 4" Pop-in Wheel for Plastic Creepers. Shipping wt. 1 lb.

96132 REPLACEMENT WHEELS FOR LOW PROFILE STEEL CREEPERS  
2" Oil resistant plastic ball bearing wheel offers a quiet, easy glide even over rough floors. Includes cap nut.  
Specifications:  
Wheel, 2" dia.  
Overall Height, 2 1/2"

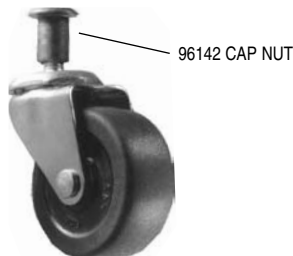

For models  
92102, 93102,  
94102, 92032,  
93032 & 94032.



96572 LARGE CREEPER WHEELS FOR PLASTIC CREEPERS  
Works especially well on cracked or uneven floor surfaces and under heavy loads. Rollers also fit the conventional Lisle plastic creeper models 92102, 93102 and 94102, so you can interchange rollers or retrofit your conventional plastic creeper.  
Specifications:  
Wheel, 4" dia.  
Overall Height, 5 1/8"



For models  
92102, 93102  
& 94102.

92132 POP-IN WHEEL FOR PLASTIC CREEPERS  
2" Urethane wheel resists corrosion. Metal compression ring holds wheel stem in groove, yet pulls free when pressure is applied.  
Specifications:  
Wheel, 2" dia.  
Overall Height, 2 3/4"



# SPECIALTY TOOLS FOR THE HEAVY DUTY TECHNICIAN

CATEGORY	PAGE	Fastener	8, 9
Tech Favorites	1	Feeler Gauges	10
Suspension & Engine	2	Battery	11
Test & Electrical	3, 4	General	11 - 17
Bearing	5	Tool Storage	17, 18
Filter	5, 6	Lubrication Products	19, 20
Torx®	7, 8	Mechanic's Creepers	21, 22

## NUMERIC INDEX

PART	DESCRIPTION	PAGE			
11120	Battery Brush	11	40900	Red 1/2" Magnetic Socket Holder	18
11420	Hose Cutter	13	40990	Green 1/2" Magnetic Socket Holder	18
13600	Standard Hex Bit Set	8	41500	Pickle Fork Kit	2
14100	Valve Core Tool	11	42090	Air Line Disconnect Set	1
14500	Oil /Fuel Filter Socket for 6.0L Ford Diesel	6	42150	Standard Hex Key Set	8
14600	Fuel Filter Socket, 5.9L Cummins	5	42300	Metric Hex Key Set	8
15000	Engine Cylinder Hone	2	42500	Standard Long Arm Hex Key Set	8
17100	Flat Band Hose Clamp Pliers	12	42650	Metric Long Arm Hex Key Set	8
17432	18 Gallon Oil Lift Drain	19	43620	Ball Joint / Truck Brake Anchor Pin / U-Joint Press	2
17892	Transmission Drain Funnel	19	44000	Tubing Bender	13
17942	Black 4.5 Gallon Pan	20	44480	Hose Clamp Vise	12
17952	Green 4.5 Gallon Pan	20	44900	Lock Ring Pliers	9
17962	Filter Preload Pan	20	45900	Hood Prop	11
18700	Hot Sleeve	16	46000	Combination Internal / External Snap Ring Pliers	9
19122	Truck Drain on Wheels	19	49000	Truck Spring Cage Bolt Socket	1
19852	Truck & Trailer Wheel Pan	19	49200	Heavy Duty Internal / External Snap Ring Pliers	9
20130	Magnetic Glove Dispenser	17	49960	Locking Air Tool Holder	18
20500	Ring Compressor	2	50000	Mini-Cutter	13
20750	Remote Starter	3	50350	Side Winder Air Hose Reel	15
21000	Ring Compressor	2	50950	Truck and Tractor Oil Filter Pliers	5
21260	Arm Glove	16	51000	Heavy Duty Scraper	12
21300	13" Magnetic Tool Holder	18	51200	Swivel Jaw Filter Wrench Pliers	5
21400	24" Magnetic Tool Holder	18	52000	Razor Blade Scraper	12
21500	Ring Compressor	2	53100	Adjustable Oil Filter Wrench	6
21520	Truck Pedal Depressor	1	53250	"Swivel Grip" Oil Filter Wrench	6
22500	Thermostat Gasket Cleaner	15	54150	Battery Terminal & Wiper Arm Puller	11
22850	Hose Pinchers	14	54200	"Swivel Grip" Oil Filter Wrench	6
24550	Computer Safe Circuit Tester	4	54300	"Swivel Grip" Oil Filter Wrench	6
26000	Tamper Resistant Torx® Bit Set	7	55400	Grounding Clamp	3
26280	Torx® Socket Set	8	56650	Adjustable Seal Puller	5
26450	Master Torx® Set	8	56750	Seal Puller	5
26530	Master Tamper Resistant Torx® Bit Set	7	57850	Battery Carrier	11
26550	Torx® Bit Set	7	59000	Ratcheting Serpentine Belt Tool	16
26750	Torx® Socket Set	8	62900	Super Out Set	9
27200	Torx® Bit Set	7	63500	"Big Range" Filter Wrench	6
28500	Strap Wrench	16	66500	Telescoping Magnetic Pocket Pick-up Tool	14
28850	Circuit Tester Pliers	3	67950	Standard Feeler Gauge	10
28890	Truck Anchor Pin Bushing Driver	1	68000	Mini Feeler Gauge	10
28950	Truck Wheel Stud Installer	1	68050	Valve Tappet Feeler Gauge	10
29200	3/8" Drive Hand Impact Tool Set	9	68100	Delux Feeler Gauge	10
29500	High-Low Circuit Tester	4	68150	Go-No-Go Feeler Gauge	10
30200	1/2" Drive Hand Impact Tool Set	9	70500	Tap Socket Set	13
30280	Automatic Center Punch	14	70940	Tap Socket Set	13
31000	Magnetic Pick-up Tool	14	75000	Vacuum Pump	3
31250	Magnetic Pick-up Tool	14	75200	Vacuum Testing / Brake Bleeding Kit	3
31800	Scribe	14	75500	Combustion Leak Detector	17
31840	"O" Ring and Seal Pick	14	75730	Combustion Leak Detector Fluid for Diesel	17
32050	Telescoping Mirror	14	92032	Red Large Wheel Creeper	21
32150	Power / Ground Outlet	4	92102	Red Low Profile Plastic Creeper	21
32250	Flexible Flashlight	15	92132	2" Pop-in Wheel for Plastic Creepers	22
32900	Heavy Duty Circuit Tester / Jumper	4	93032	Yellow Large Wheel Creeper	21
33850	Metric Hex Bit Set	8	93102	Yellow Low Profile Plastic Creeper	21
34400	Exhaust / Tailpipe Stretcher	17	93402	Creeper Seat / Step	21
35900	LED Flexible Flashlight	15	94032	Blue Large Wheel Creeper	21
37600	Super Torx® Set	7	94102	Blue Low Profile Plastic Creeper	21
37940	12 Pc. Super Torx® Bit Set	8	95002	Fold Up Creeper	21
38750	15" Diameter No Splatter Pad	20	96102	36" Low Profile Steel Creeper	22
38780	22" Square No Splatter Pad	20	96132	Wheel for Steel Creepers	22
39110	Pitman Arm Remover for Trucks	1	96142	Cap Nut for 96132	22
40200	Red 3/8" Magnetic Socket Holder	18	96202	42" Low Profile Steel Creeper	22
40210	Green 3/8" Magnetic Socket Holder	18	96302	42" Padded Low Profile Steel Creeper	22
			96572	4" Pop-in Wheel for Plastic Creepers	22